

Series 2500/25X

Roller Bearing Gear Pumps and Motors

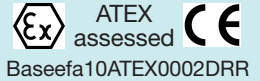

- Single or multiple units available.
- Displacement 21 cc/rev to 105 cc/rev.
- Gear widths 1/2" to 2.1/2".
- Minimum operating speed 400 rpm.
- Maximum continuous operating speed 2000 rpm.
- Maximum continuous operating pressure 2250 psi (155 bar).
- Drive shaft PL factor 9000.
- Cast iron construction.
- Double bearing option available for side load applications.

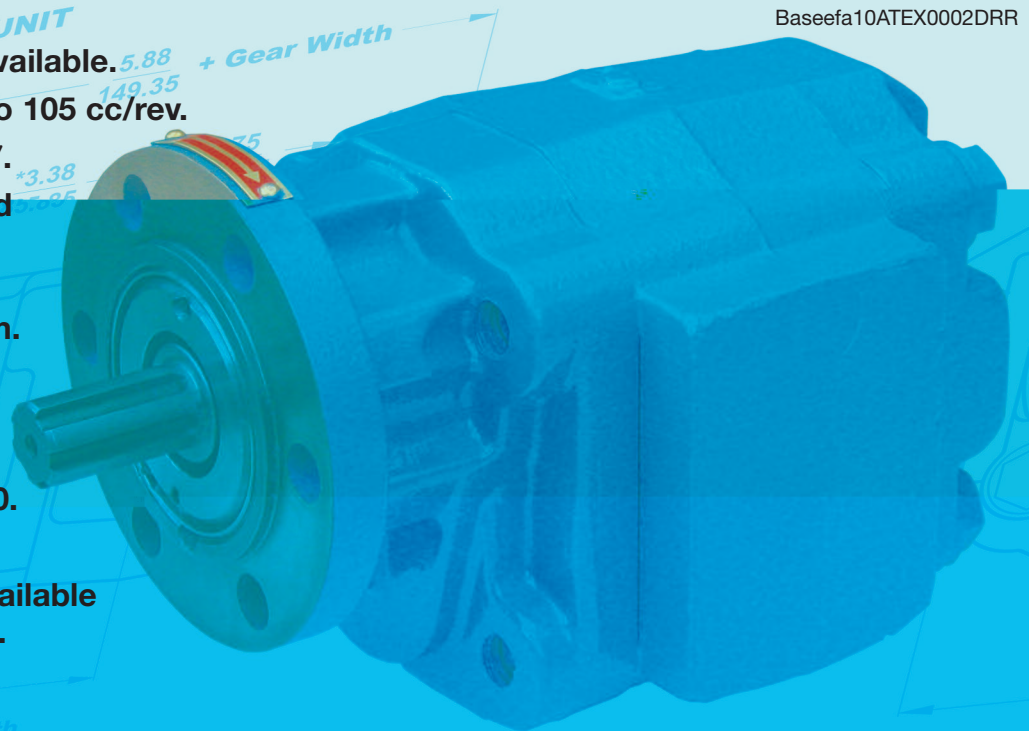

SINGLE UNIT

Mounting Flange Options:

SAE 'B' 2 bolt, SAE 'B' 4 bolt, SAE 'C' 2 bolt, SAE 'C' 4 bolt, 6 bolt round.

Drive Shaft Options:

6 tooth, SAE 'B' 13 tooth, SAE 'C' 14 tooth, SAE 'B' keyed, 1.1/8" keyed, SAE 'C' keyed.

Various Porting Options:

BSP, SAE, NPT, JIC (ODT).

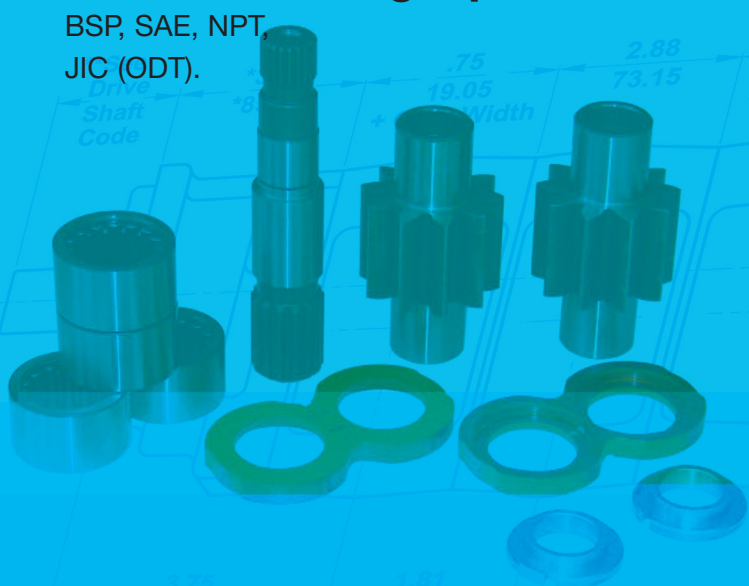

Recommended Operating Conditions:

Fluid viscosity, normal operating conditions 16 to 220 cst.
 Fluid temperature should not exceed 65 deg. C.
 Fluid cleanliness, 25 micron filter with Bio rating is recommended.
 Inlet pressure; for best operation with mineral oil, pressure should not exceed minus 0.237 bar (7 in HG).

Performance and Dimensions overleaf

Please discuss your application with our sales engineers.

Series 2500 Pumps and Motors

PERFORMANCE DATA

Pump Performance

Output- L/min/igpm – Input-Kw/Horsepower ▶					Input Speed – rpm								
					1000		1500		1800				
Gear widths – code		Gear widths – inches		Displacement – cc/rev		Maximum continuous working pressure – bar/psi		Output	Input	Output	Input	Output	Input
05	1/2	21	155/2250	18 / 4.0	6 / 8	29 / 6.3	9 / 12	34 / 7.5	11 / 15				
07	3/4	32	155/2250	27 / 5.9	8 / 11	43 / 9.5	14 / 18	51 / 11.2	17 / 23				
10	1	42	155/2250	36 / 7.8	11 / 15	57 / 12.6	18 / 24	68 / 15.0	22 / 30				
12	1.1/4	52	138/2000	46 / 10.1	14 / 18	72 / 15.9	22 / 30	87 / 19.2	26 / 35				
15	1.1/2	63	138/2000	54 / 11.9	16 / 21	87 / 19.2	26 / 35	106 / 23.3	31 / 41				
17	1.3/4	74	138/2000	67 / 14.8	18 / 24	102 / 22.5	30 / 40	124 / 27.3	36 / 48				
20	2	84	138/2000	73 / 16.1	21 / 28	115 / 25.3	34 / 46	139 / 30.6	41 / 54				
22	2.1/4	95	138/2000	80 / 17.6	23 / 31	126 / 27.8	38 / 51	155 / 34.1	46 / 61				
25	2.1/2	105	138/2000	88 / 19.4	26 / 35	141 / 31.2	43 / 57	173 / 38.1	51 / 69				

- Flows quoted are at test pressures of 138 bar/2000 psi, using 32cSt oil at 65 deg C.
- Performance data is derived from tests conducted to simulate working conditions. Continuous operation at maximum performance may compromise unit life.

If in doubt when specifying, please consult our sales department.

Motor Performance

				Output Speed – rpm				
				800	1200	1600	2000	
Gear widths – code	10	1	Input flow, Output hp & torque	Output Kw / hp	6.5 / 9.0	10.0 / 13.5	13.0 / 17.5	15.5 / 21.0
				Output Nm / in.lb	82.5 / 730	81.5 / 720	80.0 / 710	76.0 / 670
				Input l.min / igpm	41.5 / 9.0	60.5 / 13.5	77.5 / 17.0	96.5 / 21.0
	15	1.1/2		Output Kw / hp	10.5 / 14.0	15.5 / 21.0	20.0 / 27.0	24.0 / 32.5
				Output Nm / in.lb	129.0 / 1140	127.0 / 1120	124.5 / 1100	117.5 / 1040
				Input l.min / igpm	60.5 / 13.5	87.0 / 19.0	115.0 / 25.5	143.5 / 31.5
	20	2		Output Kw / hp	14.0 / 18.5	21.0 / 28.0	27.5 / 37.0	33.0 / 44.5
				Output Nm / in.lb	173.0 / 1530	169.0 / 1495	166.0 / 1470	159.5 / 1410
				Input l.min / igpm	81.5 / 18.0	117.0 / 26.0	153.0 / 34.0	189.0 / 42.0
	25	2.1/2		Output Kw / hp	18.0 / 24.0	26.5 / 35.5	33.5 / 45.0	41.0 / 55.0
				Output Nm / in.lb	215.0 / 1900	211.5 / 1870	206.0 / 1820	197.0 / 1740
				Input l.min / igpm	100.0 / 22.0	141.5 / 31.0	189.0 / 41.5	234.0 / 51.5

* These gear widths are the popular sizes for motor configurations but any of the gear widths listed in the Pump performance table can be supplied.

WEIGHTS (approximate)

Gear widths (ins)	1/2	3/4	1	1.1/4	1.1/2	1.3/4	2	2.1/4	2.1/2
Single unit (kg)	16.0	18.0	20.0	22.0	24.0	26.0	28.0	30.0	32.0

For multiple unit weights, please consult our sales department.

DIMENSIONS

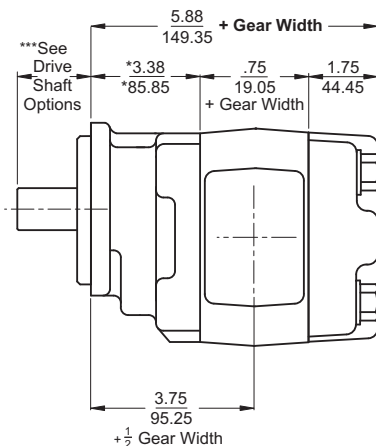

SINGLE UNIT

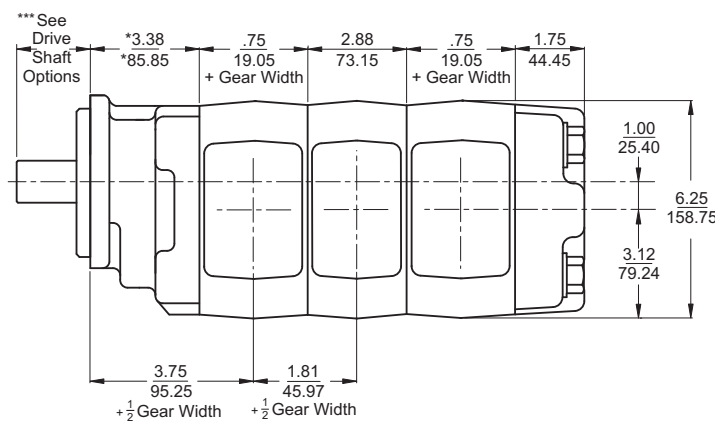

MULTIPLE UNIT

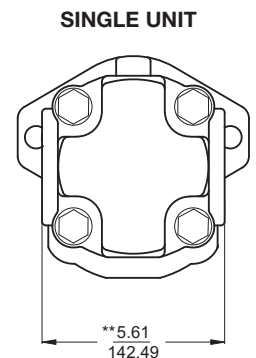

**Standard port arrangement, dimension will change with type of port.

***Dimensional information for mounting flange and shaft options are shown on the attached Data Sheet FS100.

*For double bearing option, dimensions 4.12 / 104.64

