

Series 257

Bushing Pumps and Motors

- Single or multiple units available.
- Piggy back options available.
- Displacement 21 cc/rev to 105 cc/rev.
- Gear widths 1/2" to 2.1/2".
- Minimum operating speed 600 rpm.

Maximum continuous operating speed 2400 rpm.

Maximum continuous operating pressure 4500 psi (310 bar).

Drive shaft PL factor: Integral up to 16000, Continental up to 8000.

Cast iron construction.

Compatible with mineral oil, water glycol, invert emulsion and fire resistant fluid.

Mounting Flange Options:

SAE 'B' 2 bolt, SAE 'B' 4 bolt, SAE 'C' 2 bolt, SAE 'C' 4 bolt. Pad mount.

Drive Shaft Options:



SAE 'B' 13 tooth, SAE 'BB' 15 tooth, SAE 'C' 14 tooth, 17 tooth, SAE 'BB' keyed, SAE 'C' keyed.

Various Porting Options:

BSP, SAE, NPT, JIC (ODT).

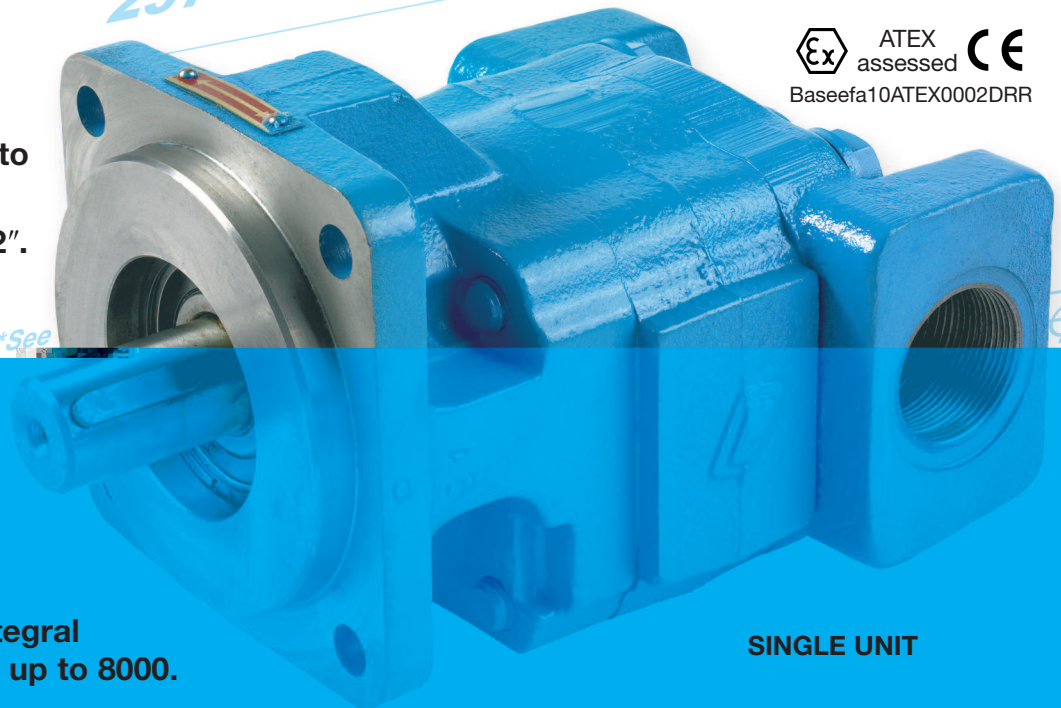
257 SERIES DIMENSIONAL DATA



 ATEX assessed

 Baseefa10ATEX0002DRR

SINGLE UNIT



MULTIPLE UNIT

Recommended Operating Conditions:

Fluid viscosity, normal operating conditions 9 to 220 cst.

Fluid temperature should not exceed 82 deg. C for mineral oil or 57 deg. C for water glycol.

Fluid cleanliness, 10 micron filter with Beta 200 rating is recommended.

Inlet pressure; for best operation with mineral oil, pressure should not exceed minus 0.237 bar (7 in HG) or with water glycol, minus 0.101 bar (3 in HG).

Performance and Dimensions overleaf

Please discuss your application with our sales engineers.

Series 257 Pumps and Motors

PERFORMANCE DATA

Pump Performance

Output- L/min/igpm – Input-Kw/Horsepower ▶						Input Speed – rpm							
						1000		1500		1800			
Output		Input		Output		Input		Output		Input			
Gear widths – code	05	Gear widths – inches	1/2	Displacement – cc/rev	21	Maximum continuous working pressure – bar/psi	310/4500	17 / 3.7	10 / 14	28 / 6.2	13 / 18	34 / 7.5	16 / 21
	07		3/4		32		310/4500	26 / 5.7	15 / 20	43 / 9.5	20 / 27	52 / 11.5	24 / 32
	10		1		42		310/4500	35 / 7.7	20 / 27	59 / 13.0	27 / 35	71 / 15.6	32 / 42
	12		1.1/4		52		310/4500	45 / 9.9	25 / 34	74 / 16.3	33 / 44	89 / 19.6	39 / 53
	15		1.1/2		63		241/3500	55 / 12.1	30 / 40	89 / 19.6	40 / 53	108 / 23.8	47 / 63
	17		1.3/4		74		224/3250	64 / 14.1	33 / 45	105 / 23.1	46 / 61	127 / 28.0	56 / 75
	20		2		84		206/3000	73 / 16.1	37 / 49	120 / 26.4	52 / 69	145 / 31.9	61 / 81
	22		2.1/4		95		189/2750	83 / 18.3	37 / 49	136 / 30.0	52 / 69	164 / 36.1	61 / 81
	25		2.1/2		105		172/2500	94 / 20.7	37 / 49	151 / 33.3	52 / 69	183 / 40.3	61 / 81

- Flows quoted are at test pressures equivalent to maximum continuous working pressures, using 32cSt oil at 65 deg C.
- When using water based fluids, the maximum continuous working pressure is reduced, please consult sales department.
- Performance data is derived from tests conducted to simulate working conditions. Continuous operation at maximum performance may compromise unit life.
If in doubt when specifying, please consult our sales department.

* These gear widths are the popular sizes for motor configurations but any of the gear widths listed in the Pump Performance table can be supplied.

Motor Performance

				Output Speed – rpm				
				800	1200	1600	2000	
Gear widths – code	10	1	Input flow, Output hp & torque	Output Kw / hp	13.5 / 18.0	18.0 / 24.0	21.8 / 29.0	26.0 / 34.6
				Output Nm / in.lb	140.5 / 1242	1414 / 1250	139.9 / 1237	136.9 / 1210
				Input l.min / igpm	50.0 / 11.0	64.1 / 14.1	77.3 / 17.0	88.6 / 19.5
				Output Kw / hp	21.0 / 28.0	28.1 / 37.4	35.0 / 46.6	40.7 / 54.3
				Output Nm / in.lb	220.6 / 1950	221.9 / 1962	2217 / 1960	214.9 / 1900
				Input l.min / igpm	69.7 / 15.4	87.7 / 19.3	107.4 / 23.7	128.2 / 28.2
	15	1.1/2		Output Kw / hp	24.2 / 32.3	32.3 / 43.0	39.8 / 53.1	46.4 / 61.8
				Output Nm / in.lb	255.9 / 2262	257.7 / 2260	252.3 / 2230	2449 / 2165
				Input l.min / igpm	88.6 / 19.5	115.0 / 25.3	153.0 / 34.0	164.0 / 36.1
				Output Kw / hp	25.3 / 33.7	33.7 / 44.9	41.6 / 55.5	48.4 / 64.5
				Output Nm / in.lb	267.2 / 2362	267.0 / 2360	263 / 2330	255.7 / 2260
				Input l.min / igpm	107.4 / 23.7	137.6 / 30.3	169.7 / 37.4	201.7 / 44.4

WEIGHTS (approximate)

Gear widths (ins)	1/2	3/4	1	1.1/4	1.1/2	1.3/4	2	2.1/4	2.1/2
Single unit (kg)	19.8	20.4	20.9	21.7	22.3	22.9	23.5	24.1	24.7

For multiple unit weights, please consult our sales department.

DIMENSIONS (inches/mm)

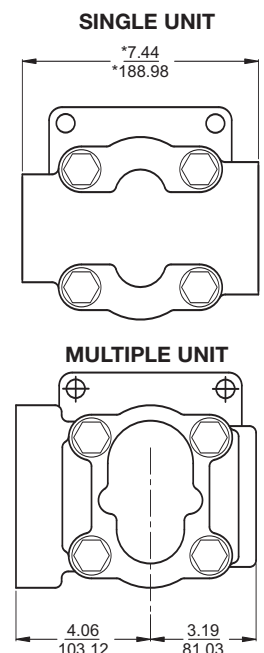
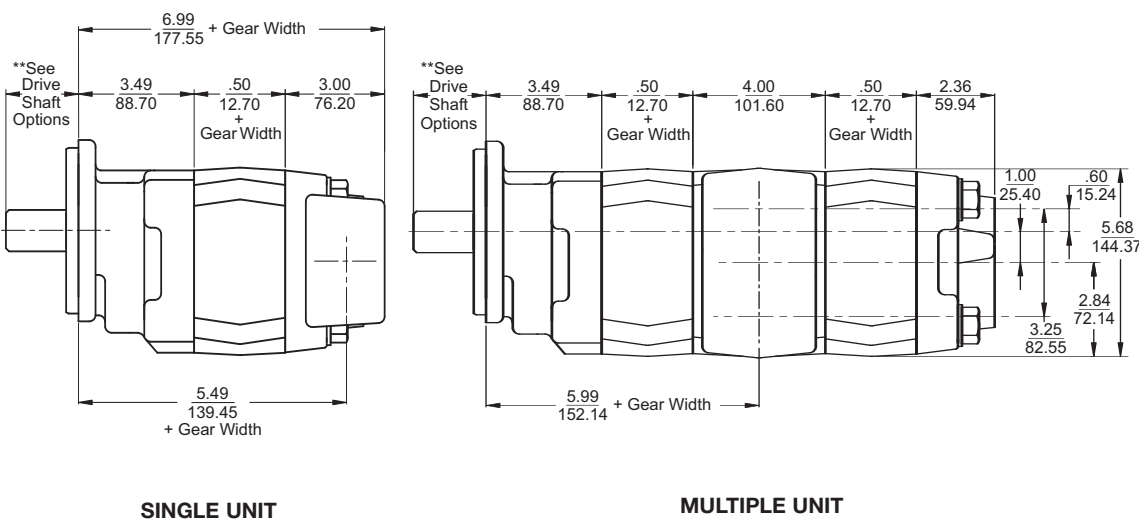

*Standard port arrangement, dimension will change with type of port.

**Dimensional information for mounting flange and shaft options are shown on the attached Data Sheet FS100.

HYDRA-PERM-CO LTD

HYDRAULIC ENGINEERS

Unit 20 Silver Court ■ Intercity Way ■ Bramley ■ Leeds ■ West Yorkshire ■ LS13 4LY ■ UK
Tel: +44 (0) 1132 361367 ■ Fax: +44 (0) 113 239 4207 ■ e-mail: info@hydra-perm.co.uk ■ website: www.hydra-perm.co.uk