

## Series 5000/50 & 5100/51

# Roller Bearing Gear Pumps, Motors and Flow Dividers

- Single or multiple units available.
- Piggy back options available.
- Type II mounting available.
- Displacement 21 cc/rev to 115.9 cc/rev.
- Gear widths 1/2" to 2,3/4".
- Minimum operating speed 400 rpm.
- Maximum continuous operating speed 2000 rpm.
- Maximum continuous operating pressure 2500 psi (172 bar).
- Drive shaft PL factor: Integral 14000, Continental 9000.
- Cast iron construction.
- Dowelled units available.

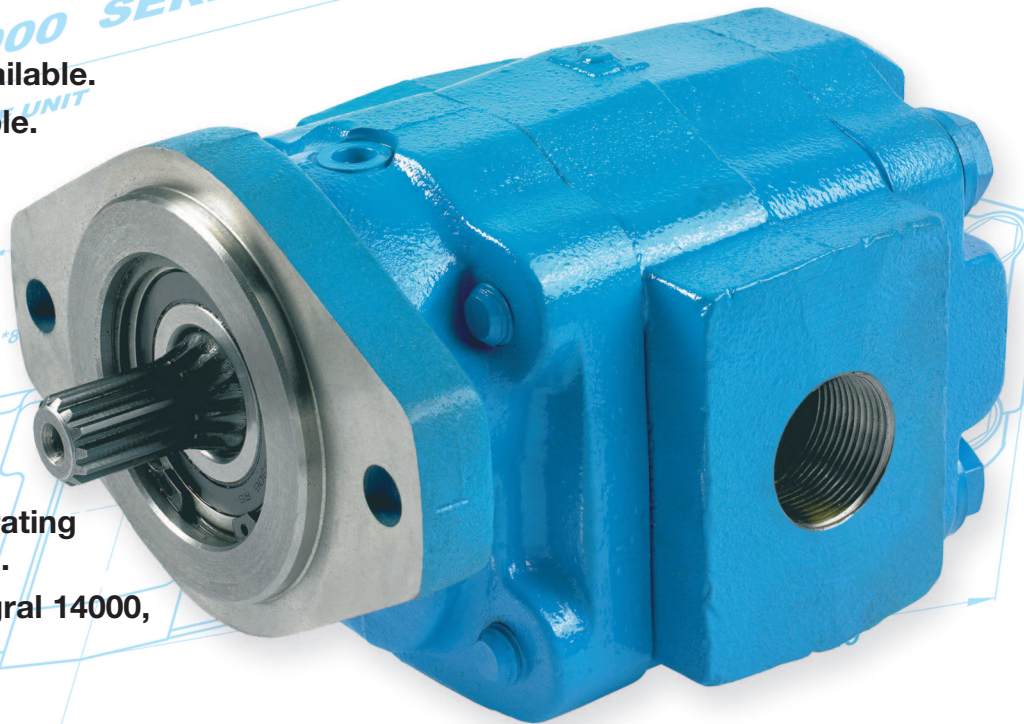

SINGLE UNIT

### Mounting Flange Options:

SAE 'B' 2 bolt, SAE 'B' 4 bolt, SAE 'C' 2 bolt, SAE 'C' 4 bolt.

### Drive Shaft Options:

SAE 'B' 13 tooth, SAE 'C' 14 tooth, SAE 'B' 15 tooth, SAE 'C' keyed, Taper shaft.

### Various Porting Options:

BSP, SAE, NPT, JIC (ODT).

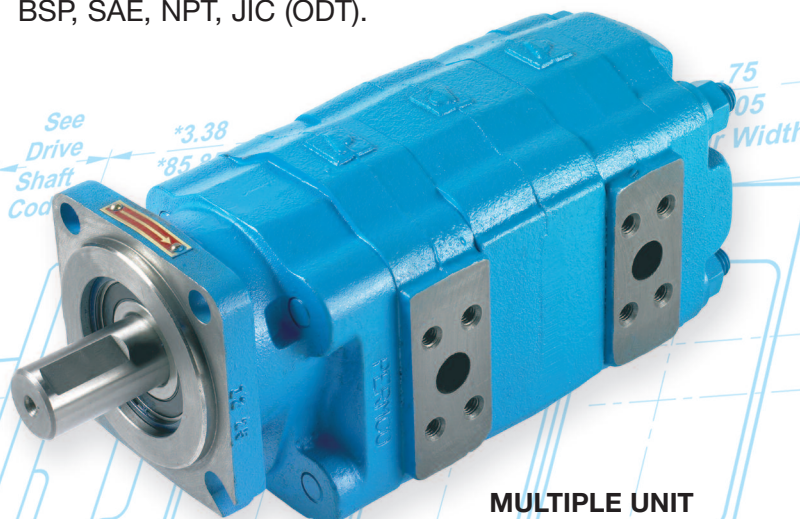
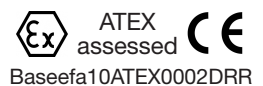

MULTIPLE UNIT

### Recommended Operating Conditions:

Fluid viscosity, normal operating conditions 16 to 220 cst.

Fluid temperature should not exceed 65 deg. C.

Fluid cleanliness, 10 micron filter with Beta 200 rating is recommended.

Inlet pressure; for best operation with mineral oil, pressure should not exceed minus 0.237 bar (7 in HG).

Performance and Dimensions overleaf

Please discuss your application with our sales engineers.

# Series 5000/50 Pumps, Motors and Flow Dividers

## PERFORMANCE DATA

### Pump Performance

Output- L/min/igpm – Input-Kw/Horsepower ▶					Input Speed – rpm						
					1000		1500		1800		
Gear widths – code		Gear widths – inches		Displacement – cc/rev	Maximum continuous working pressure – bar/psi	Output	Input	Output	Input	Output	Input
05	1/2	21	207/3000			18 / 4.0	6 / 8	29 / 6.3	9 / 12	34 / 7.5	11 / 15
07	3/4	32	207/3000	27 / 5.9	8 / 11	43 / 9.5	14 / 18	51 / 11.2	17 / 23		
10	1	42	207/3000	36 / 7.8	11 / 15	57 / 12.6	18 / 24	68 / 15.0	22 / 30		
12	1.1/4	52	207/3000	46 / 10.1	14 / 18	72 / 15.9	22 / 30	87 / 19.2	26 / 35		
15	1.1/2	63	180/2610	54 / 11.9	16 / 21	87 / 19.2	26 / 35	106 / 23.3	31 / 41		
17	1.3/4	74	180/2610	67 / 14.8	18 / 24	102 / 22.5	30 / 40	124 / 27.3	36 / 48		
20	2	84	180/2610	73 / 16.1	21 / 28	115 / 25.3	34 / 46	139 / 30.6	41 / 54		
22	2.1/4	95	155/2250	80 / 17.6	23 / 31	126 / 27.8	38 / 51	155 / 34.1	46 / 61		
25	2.1/2	105	155/2200	88 / 19.4	26 / 35	141 / 31.2	43 / 57	173 / 38.1	51 / 69		

- Flows quoted are at test pressures of 138 bar/2000 psi, using 32cSt oil at 65 deg C.
  - 2.3/4" gear width also available, ask sales engineers for details.
  - Dowelled units also available 5100/51.
  - Performance data is derived from tests conducted to simulate working conditions. Continuous operation at maximum performance may compromise unit life.
- If in doubt when specifying, please consult our sales department.*

### Motor Performance

				Output Speed – rpm			
				800	1200	1600	2000
Gear widths – code	10	1	Output Kw / hp	6.5 / 9.0	10.0 / 13.5	13.0 / 17.5	15.5 / 21.0
			Output Nm / in.lb	82.5 / 730	81.5 / 720	80.0 / 710	75.0 / 670
			Input l.min / igpm	41.0 / 9.0	61.5 / 13.5	77.5 / 17.0	95.5 / 21.0
			Output Kw / hp	10.5 / 14.0	15.5 / 21.0	20.0 / 27.0	24.0 / 32.5
	15	1.1/2	Output Nm / in.lb	129.0 / 1140	126.5 / 1120	124.5 / 1100	117.5 / 1040
			Input l.min / igpm	61.5 / 13.5	86.5 / 19.0	116.0 / 25.5	143.0 / 31.5
			Output Kw / hp	14.0 / 18.5	21.0 / 28.0	27.5 / 37.0	33.0 / 44.5
			Output Nm / in.lb	173.0 / 1530	169.0 / 1495	166.0 / 1470	159.5 / 1410
	20	2	Input l.min / igpm	82.0 / 18.0	116.0 / 25.5	154.5 / 34.0	188.5 / 41.5
			Output Kw / hp	18.0 / 24.0	26.5 / 35.5	33.5 / 45.0	41.0 / 55.0
			Output Nm / in.lb	214.5 / 1900	211.5 / 1870	205.5 / 1820	196.5 / 1740
			Input l.min / igpm	100.0 / 22.0	141.0 / 31.0	188.5 / 41.5	234.0 / 51.5

- \*These gear widths are the popular sizes for motor configurations but any of the gear widths listed in the Pump Performance table can be supplied.

### WEIGHTS (approximate)

Gear widths (ins)	1/2	3/4	1	1.1/4	1.1/2	1.3/4	2	2.1/4	2.1/2	2.3/4
Single unit (kg)	17.0	18.5	19.5	20.5	21.0	22.0	22.5	23.5	24.5	25.5

For multiple unit weights, please consult our sales department.

### DIMENSIONS

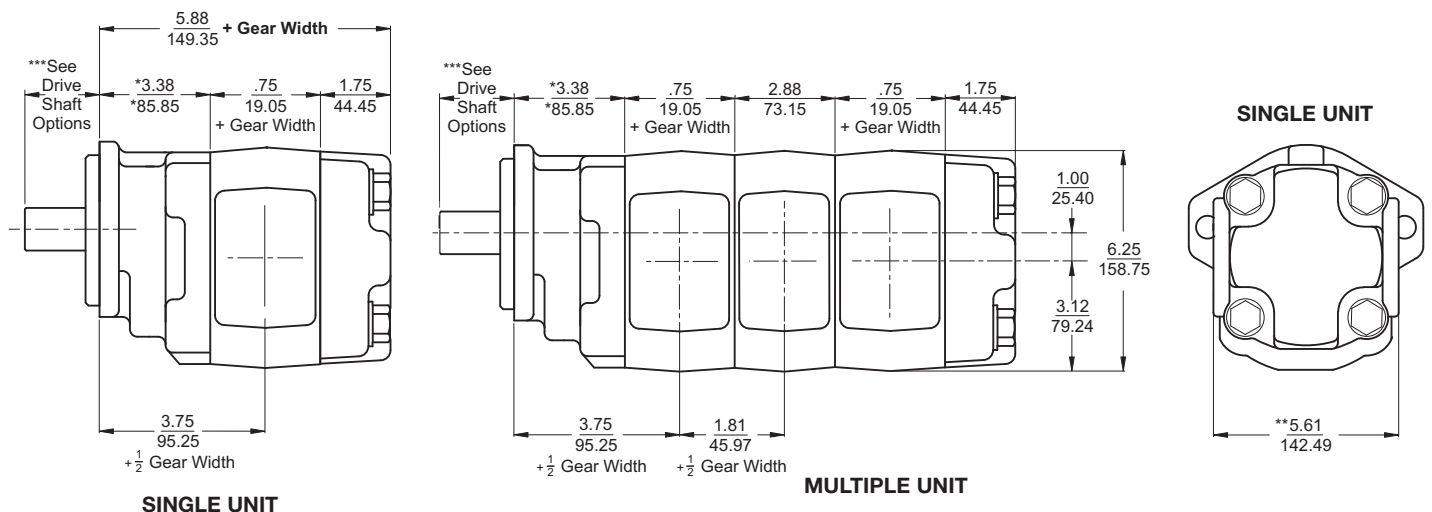

\*Dimensions for Type II mounting  $\frac{2.39}{60.70}$

\*\*Standard port arrangement, dimension will change with type of port.

\*\*\*Dimensional information for mounting flange and shaft options are shown on the attached Data Sheet FS100.



SSH Permco Inc.

MZ-3 Bansi Trade Center

581/5 M.G. Road Indore-452001 (M.P.) India

Phone : +91-731-4064679 | Email: info@sshpermcoindia.com